

THIS DRAWING IS UNPUBLISHED. RELEASED FOR PUBLICATION .19  
 (C) COPYRIGHT 19 BY AMP INCORPORATED. ALL RIGHTS RESERVED.

| LOC | DIST | REVISIONS   |                         |         |       |
|-----|------|-------------|-------------------------|---------|-------|
| P   | LTR  | DESCRIPTION | DATE                    | DWN     | APVD  |
| CM  | 52   | F           | REV PER EC 0L30-0015-97 | 2-21-97 | JH RS |

- MATES WITH HOUSING 640519.
- UL LOGO AND CSA LOGO TO APPEAR ON EITHER LATCH SURFACE PER AMP SPEC 202-20, I.D. NO. 1-18838-3 AND 1-18839-3. FROST BACKGROUND OPTIONAL.
- DIMENSIONS IN BRACKETS ARE IN INCHES.

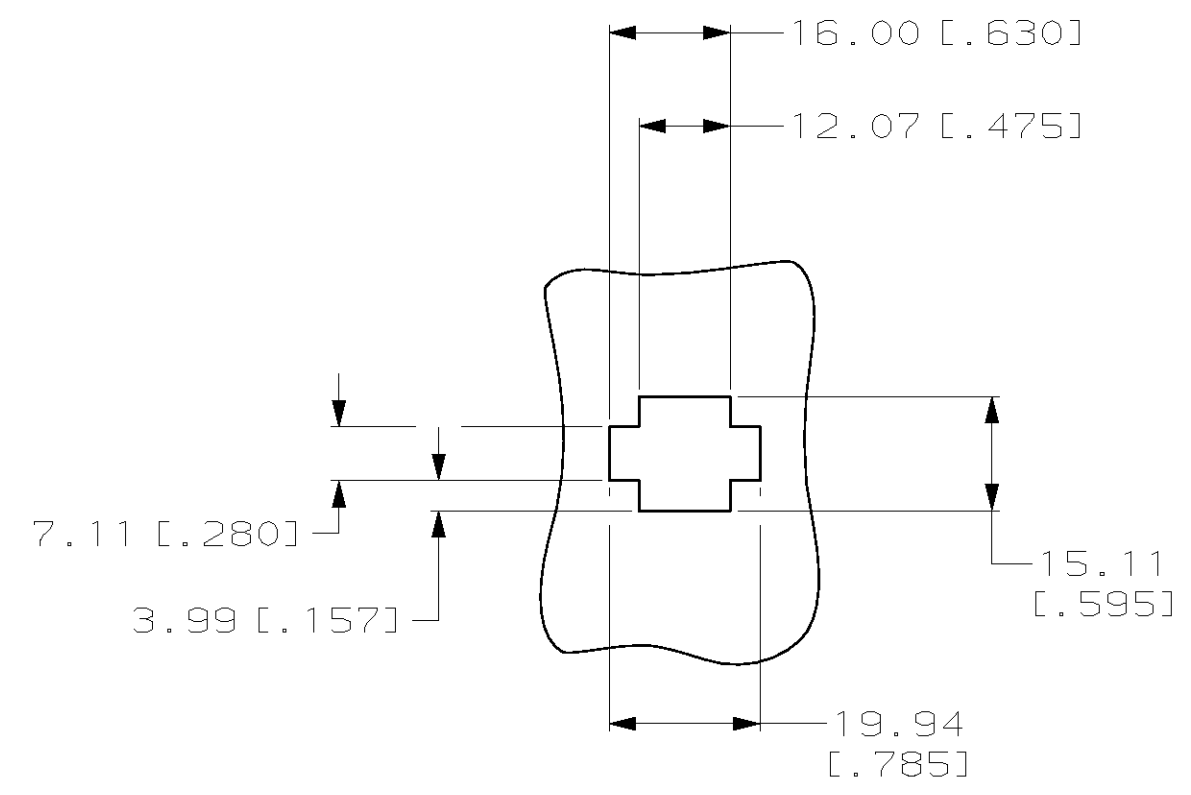
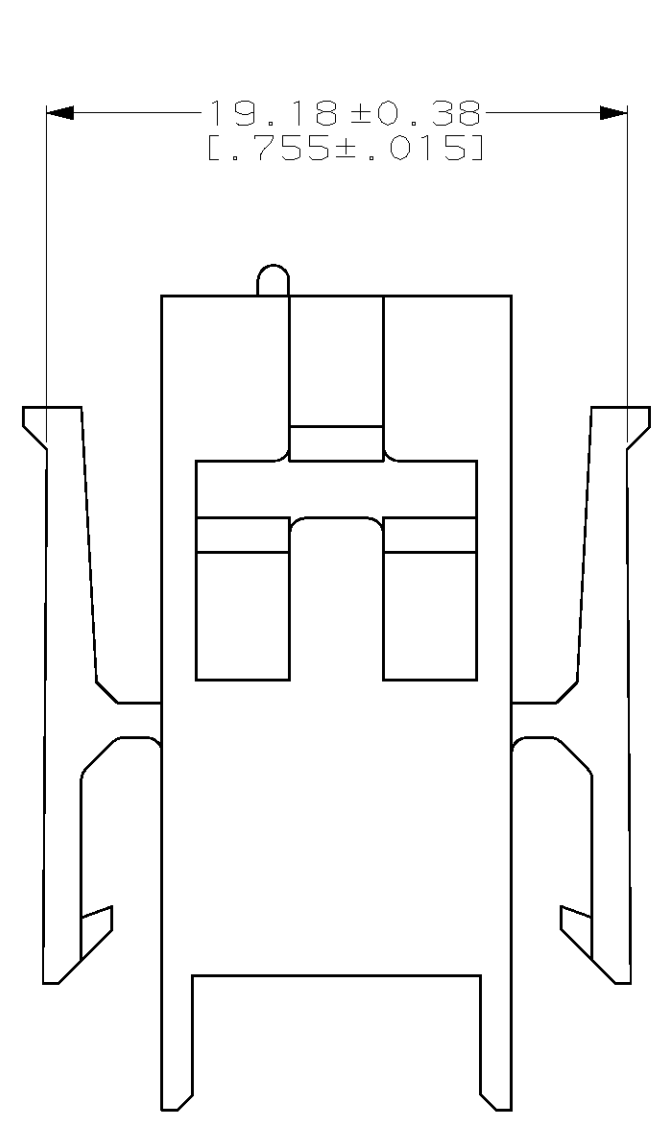
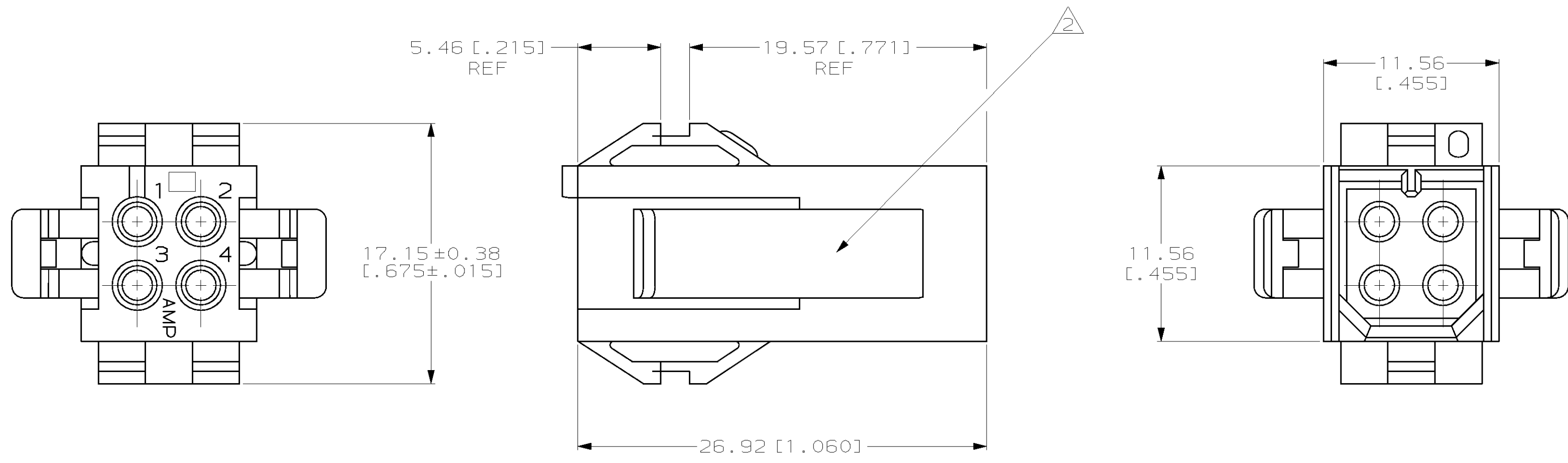

RECOMMENDED CUT OUT  
 FOR 1.73 [.068] MAX THICK PANEL  
 SCALE 1:1

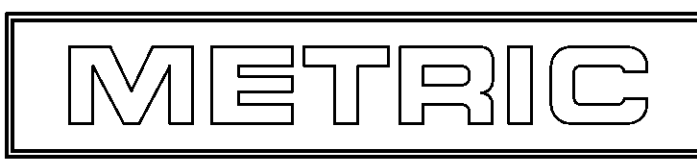

1-640509-0  
 PART NUMBER

|   |  |                  |                                    |         |   |          |
|---|--|------------------|------------------------------------|---------|---|----------|
| THIS DRAWING IS A CONTROLLED DOCUMENT.  |  | DWN              | R. VESTAL                          | 7-12-96 | AMP Incorporated<br>Harrisburg, PA 17105-3608 |          |
| DIMENSIONS:   |  | CHK              | R. SWING                           | 7-12-96 |   |          |
| mm [INCHES]   |  | APVD             | A. BEDDICK                         | 7-12-96 |   |          |
| TOLERANCES UNLESS OTHERWISE SPECIFIED:<br>0 PLC ±-<br>1 PLC ±-<br>2 PLC ±0.13 [.005]<br>3 PLC ±-<br>4 PLC ±-<br>ANGLES ±0°30' |  | NAME             | HOUSING, CAP<br>MRII<br>4 POSITION |         |   |          |
| MATERIAL NYLON, UL 94V-0, NATURAL (BRICK RED)   |  | PRODUCT SPEC     | -                                  |         | SIZE  | A2       |
| FINISH -  |  | APPLICATION SPEC | -                                  |         | CAGE CODE                                     | 00779    |
|   |  | WEIGHT           | -                                  |         | DRAWING NO                                    | C-640509 |
|   |  | CUSTOMER DRAWING |                                    |         | SCALE   | 4:1      |
|   |  |                  |                                    |         | SHEET   | 1 OF 1   |
|   |  |                  |                                    |         | REV   | F        |